

This note describes a determination method for Vitamin B1 (chemical name: thiamine) using HPLC coupled with post-column derivatization.

Vitamin B1 exists not only as free thiamine itself but also as its phosphate derivatives. In this note, to determine the total amount of vitamin B1, thiamine phosphate esters were converted to thiamine by utilizing enzymatic reaction. After purification procedures, the sample solutions were injected into the HPLC system.

Thiamine in injected solution is separated from other

compounds in the ODS column, reacted with potassium ferricyanide under alkaline condition, and determined by fluorescence detector with high sensitivity and selectivity.

Sample pretreatment was performed with solid-phase extraction (SPE) instead of permutit (activated zeolite resin) method, which is established by Japanese Food Sanitation Inspection Guidelines. SPE is also described as reference method in the guidelines and offered easy way to remove impurities.

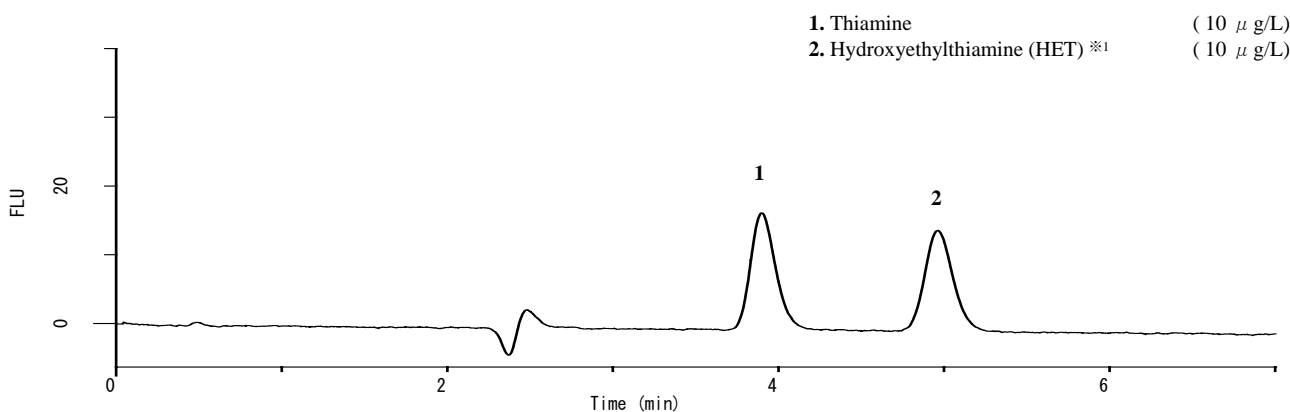

A chromatogram obtained from standard solution

※1: Hydroxyethylthiamine is also included in vitamin B1.

### A diagram for the HPLC system

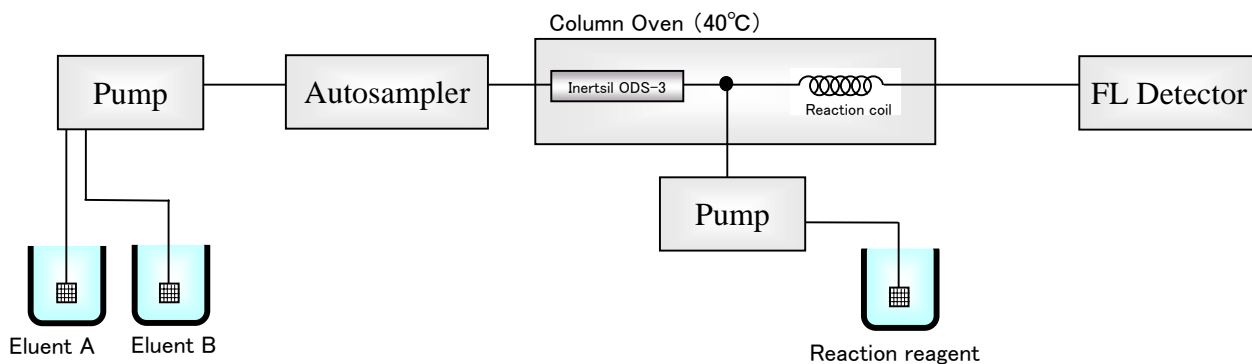

#### Conditions

- Column Inertsil ODS-3 (5 μm, 150 x 4.6 mm I.D.)  
Cat.No. 5020-01731
- Col. Temp. 40°C
- Detection FL Ex. 375 nm, Em. 440 nm
- Inj. Vol. 20 μL
- Eluent : A) CH<sub>3</sub>OH B) Phosphate buffer\*  
A/B = 1/9, v/v
- Flow rate : 0.8 mL/min
- Reaction reagent  
: 0.05% (w/v) K<sub>3</sub>[Fe(CN)<sub>6</sub>] and 15% (w/v) NaOH aqueous solution, 0.4 mL/min
- Reaction coil: 5 m x 0.33 mm I.D.

\* Phosphate buffer: To 0.01 M sodium dihydrogen phosphate aqueous solution, 0.15 M sodium perchlorate aqueous solution was added and adjusted the pH to 2.2.

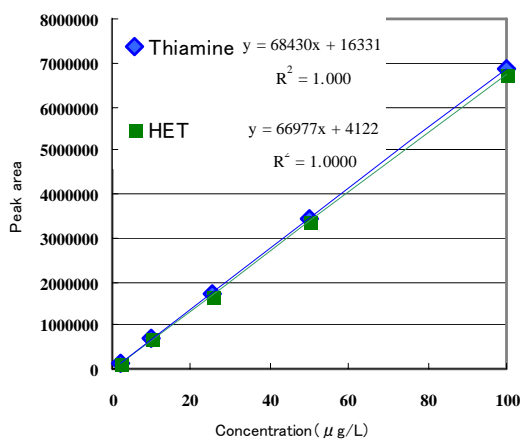

The calibration curves

## An example of pretreatment for food samples

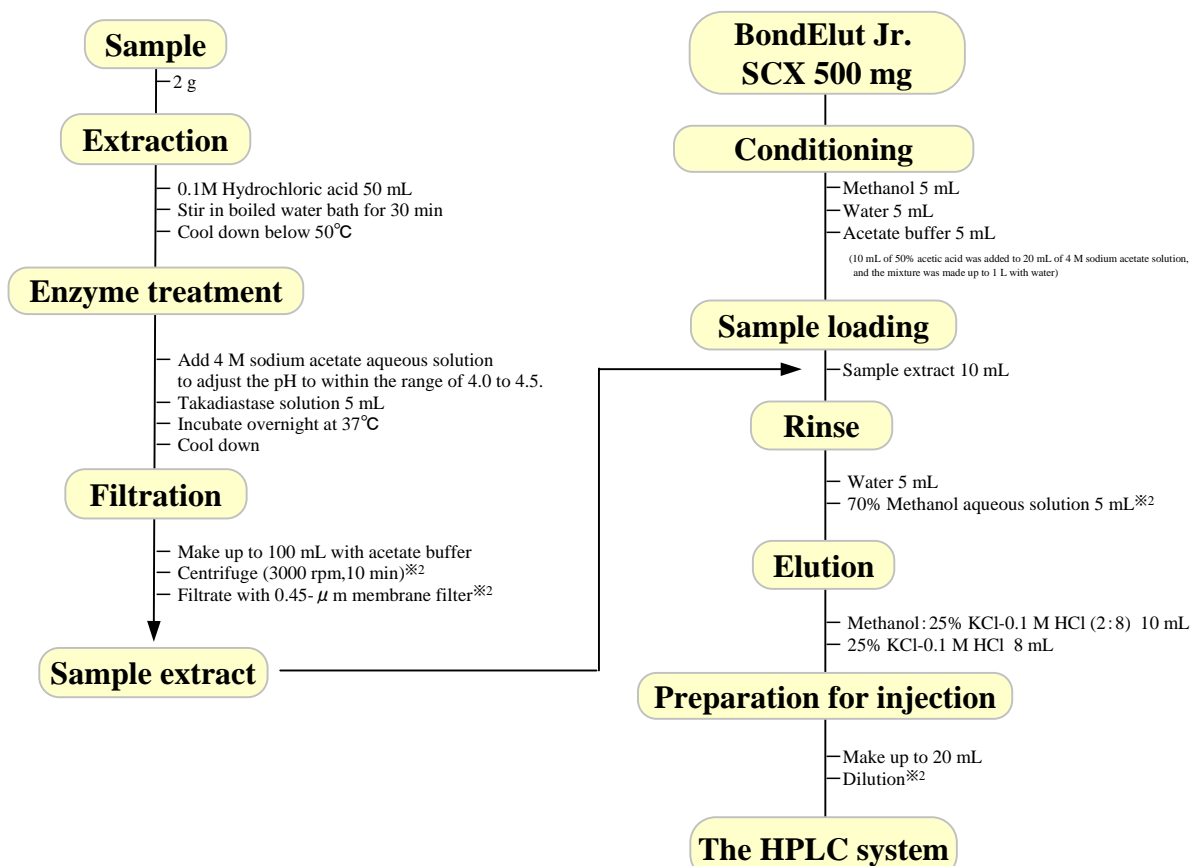

※2: These procedures should be performed as necessary.

### Thiamine phosphate esters

A chromatogram shown below is obtained from a sample without any enzyme pretreatment. To measure the total vitamin B1, enzyme pretreatment have to be performed.

1. Thiamine triphosphate
2. Thiamine diphosphate
3. Thiamine monophosphate
4. Thiamine
5. HET (100 µg/L each)

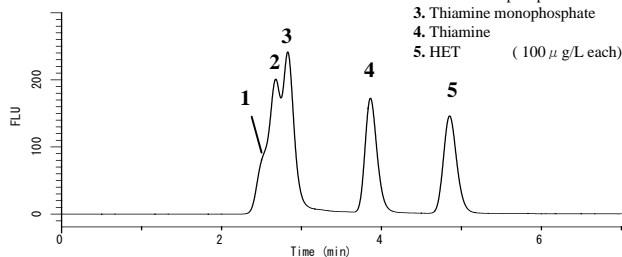

### Recovery ratio of solid-phase extraction

	Thiamine	HET
Recovery (%)	98.8	99.3
C.V. (%)	1.6	1.5

(50 µg/L each in distilled water, N=5)

### The effect of solid-phase extraction (sample: extract from broiled eel)

A sample solution without solid-phase extraction

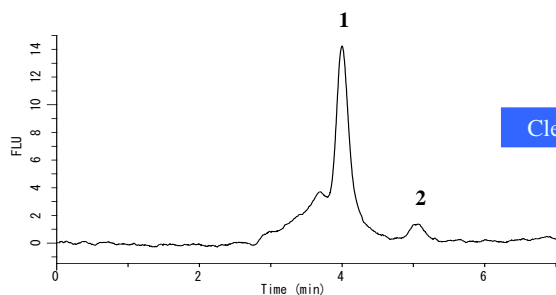

A sample solution after solid-phase extraction

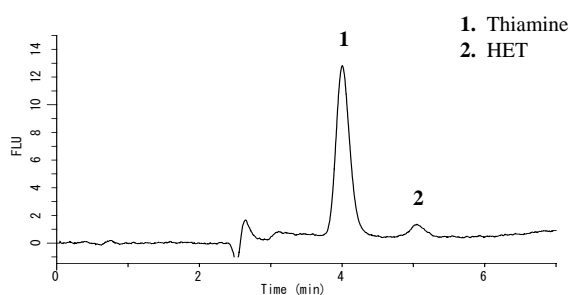

1. Thiamine
2. HET

## Examples of vitamin B1 determination in food samples

### Pork extract

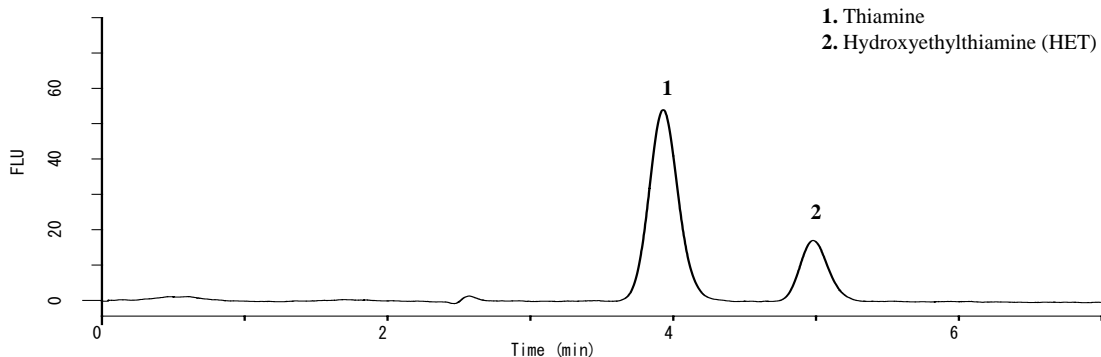

### Spinach extract

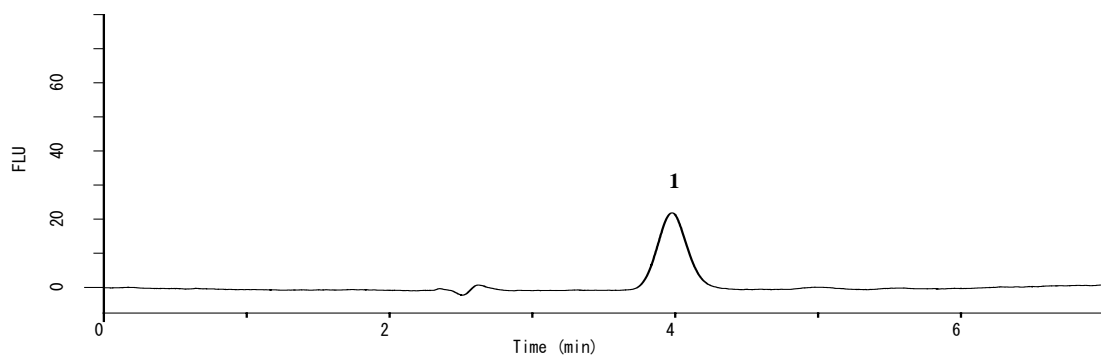

### Extract from powdered milk

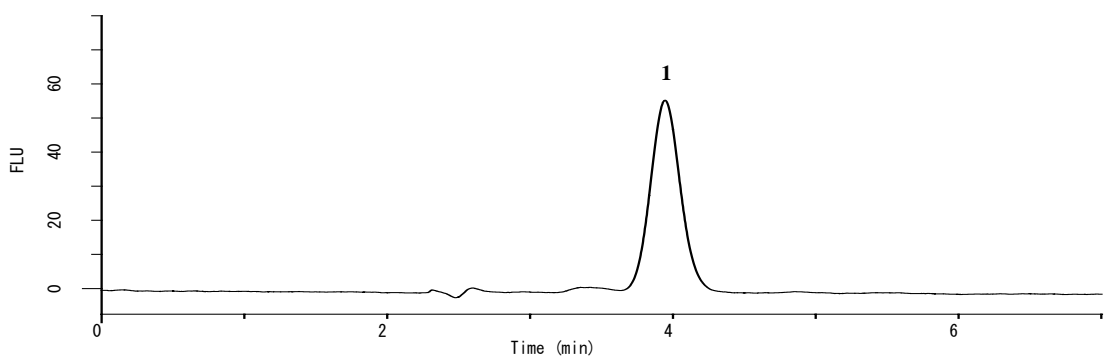

## Thiochrome reaction

Thiochrome is a blue fluorescent compound and produced by the reaction of thiamine in alkaline solution with oxidizing agent, such as potassium ferricyanide or cyanogen bromide. The reaction is often used for the determination of vitamin B1.

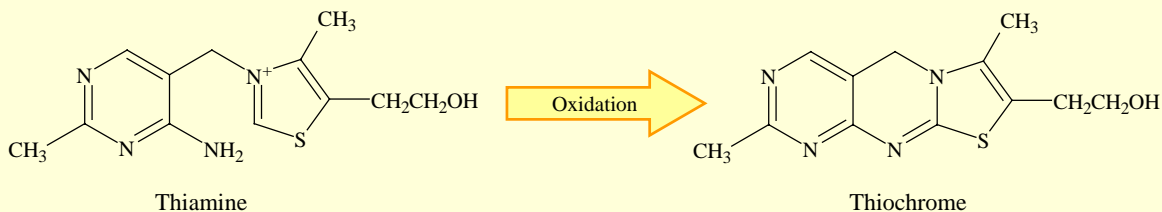

## Inert Family

“Inertsil” High Performance LC Column

“InertCap” GC Capillary Column

“InertSep” Solid Phase Extraction for pretreatment of analysis



## Visit our Website on

<http://www.glsciences.com/>

<http://www.inertsil.com/>

GL Sciences also offers an extensive range of GC and LC consumables.

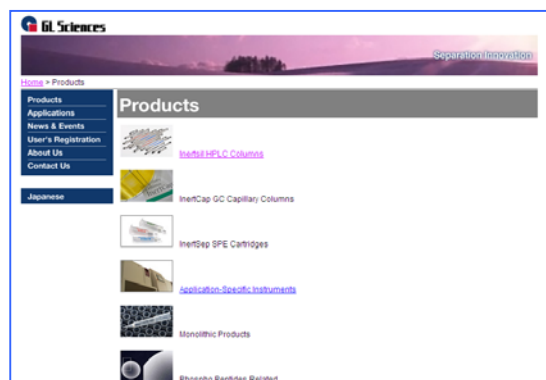

## Contact us

### **GL Sciences, Inc. Japan**

22-1 Nishishinjuku 6-chome, Shinjuku-ku, Tokyo, 163-1130 Japan

TEL: +81-3 (5323)6620 FAX: +81-3 (5323)6621

### **GL Sciences, Inc. USA**

4733 Torrance Blvd. Ste 255, Torrance, CA 90503

Tel: (310)265-4424 FAX (310)265-4425

### **Distributors Outside of Japan and USA**

GL Sciences uses distributors in many countries.

You can find a local distributor in your country in the following url.

<http://www.glsciences.com/products/contact.html>

E-MAIL: [world@gl.co.jp](mailto:world@gl.co.jp)

